

# Clantrac®

## STRONG-ARM



### VEHICLE POSITIONING JACK

MODEL NO: VPJ300

PART NO: 7624100

### OPERATION AND MAINTENANCE INSTRUCTIONS

UK  
CA | CE

ORIGINAL INSTRUCTIONS

DL0624 Rev 6

---

## INTRODUCTION

---

Thank you for purchasing this CLARKE Vehicle Positioning Jack.

Before attempting to use this product, please read this manual thoroughly and follow the instructions carefully. In doing so you will ensure the safety of yourself and that of others around you and you can look forward to your purchase giving you long and satisfactory service.

Keep these instructions for future reference.

---

## GUARANTEE

---

This product is guaranteed against faulty manufacture for a period of 12 months from the date of purchase. Please keep your receipt which will be required as proof of purchase.

This guarantee is invalid if the product is found to have been abused or tampered with in any way, or not used for the purpose for which it was intended.

Faulty goods should be returned to their place of purchase, no product can be returned to us without prior permission.

This guarantee does not effect your statutory rights.

---

## SPECIFICATIONS

---

Dimensions (L x W x H)	540 x 630 x 330 mm
Weight	17.8 kg
Roller distance (min-max)	345 - 630 mm
Rated Load per wheel/jack	680 kg
Maximum vehicle weight	2720 kg
Maximum tyre width	300 mm (12")

---

# SAFETY PRECAUTIONS

---

## GENERAL

1. ALWAYS read and ensure you fully understand the following precautions and the hazards associated with this product. **DO NOT** allow anyone who has not read these instructions to use this jack.
2. Only use this jack for its intended purpose.
3. **NEVER** carry out any modifications to this product. If experiencing difficulty of any kind consult your local dealer.
4. **ALWAYS** use appropriate safety equipment, such as protective footwear, when using this jack.

## WORK AREA

1. **DO NOT** use the jack on inclined surfaces. It must only be used on level ground. The jack may move away as soon as it lifts the tyre from the ground surface.
2. **DO NOT** overload the jack beyond the load rating (680 kg per jack).
3. **DO NOT** start the vehicle engine with the jacks in use. The jacks are only designed for hand manoeuvring vehicles.
4. **DO NOT** use the jack to lift tyres wider than 300mm (12 inches).
5. **DO NOT** attempt to push the jack over obstacles when supporting a vehicle. It is only designed to be used on level and reasonably smooth surfaces.
6. Only use the jack on level and solid ground, preferably concrete. Never use it on soft/unmade ground as the jack may sink in.
7. Make sure that non-essential persons keep a safe distance whilst the jack is in use.
8. **ALWAYS** engage the castor wheel brakes if the jack is left unattended while supporting a vehicle. This product is not intended to support the vehicle permanently, only for moving.
9. **NEVER** work underneath a vehicle supported only by this product. If working under a vehicle, always use stands designed for the purpose.
10. **ALWAYS** the jack in a well lit work area.
11. Keep the work area clean and tidy and free from unrelated items.

## SERVICING & REPAIRS

1. Check the jack for damage before use and **DO NOT** use if damaged. Any damage should be properly repaired or the defective part replaced. If in doubt, **DO NOT** use. Do not use if an oil leak is apparent. Consult your local dealer.
2. **ALWAYS** use spare parts supplied by CLARKE International. Using non-standard parts could be extremely dangerous.
3. Ensure that the jack is properly maintained at all times and that no corrosion or other damage is allowed to weaken any part of it. **DO NOT** exceed the rated capacity of the jack.
4. When necessary, have your jack serviced or repaired by a qualified technician using identical replacement parts. This will ensure that the safety of the jack is maintained.
5. **NEVER** use the jack if it has been subjected to excess load (over 680 kg) or shock. The jack should be removed from service immediately and fully inspected by qualified personnel and passed as serviceable before being used again.
6. **Please keep these instructions in a safe place for future reference.**

## ENVIRONMENTAL PROTECTION

One of the most damaging sources of environmental pollution is oil products. Never throw away used hydraulic oil with domestic refuse or flush it down a sink or drain. Collect any hydraulic oil in a leak proof container and take it to your local waste disposal site.

If disposing of this product or any damaged components, do not dispose of with general waste. This product contains valuable raw materials and should be taken to your local civic amenity site for recycling of metal products.

## OVERVIEW

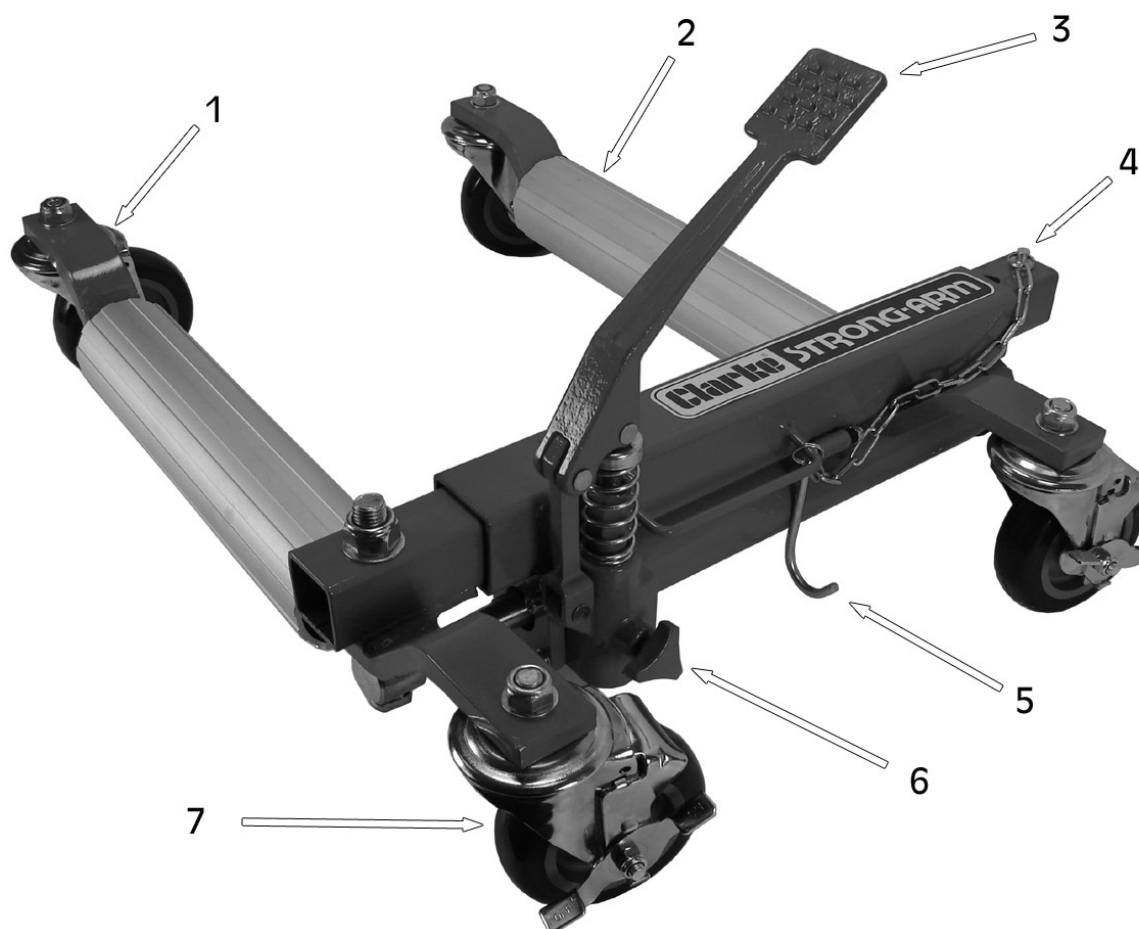

1	Beam
2	Roller
3	Operating Pedal
4	Locking Pin
5	Pedal Locking Hook
6	Release Valve Thumb Wheel
7	Castor Wheel with Brake

## UNPACKING

During transit or storage, it is possible that an air pocket may have developed within the hydraulic ram, and the ram action may therefore appear to be 'spongy'. In this case the jack may require purging.

If the jack does not reach its full height, the oil level may require topping up as described in the Maintenance section.

---

## OPERATION

---



**WARNING: MAKE SURE THAT THE SAFETY PRECAUTIONS ARE STRICTLY FOLLOWED. NO RESPONSIBILITY CAN BE ACCEPTED FOR INCORRECT USE OF THE JACK**

---

Before use, visually inspect the jack for distortion of parts, cracked welds, damaged castors, oil leaks, or any other sign of damage. Should any of these be apparent, have the jack inspected and repaired by a qualified technician before putting back into use.

1. With the jack on the floor, hold the operating pedal down to release the pedal locking hook.
2. Pull out the locking pin from the frame.
3. Open the release valve by turning the thumb-wheel counter-clockwise.
4. Expand the jack beams apart by hand, enough to position around the vehicle tyre.

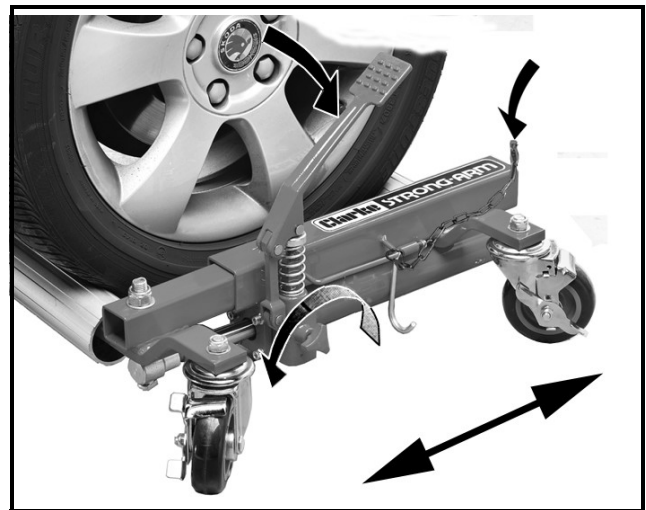

5. Close the release valve by turning the thumb-wheel clockwise until tight.
  - Ensure the jack is parallel to the sidewall of the tyre. Leave clearance between the tyre wall and the jack frame.
6. Pump the operating pedal, depressing with smooth, even strokes of the foot until both rollers are in contact with the tyre tread.
7. Continue operating the foot pedal until the tyre is lifted from the ground and one of the locking pin locating holes is accessible. Replace the locking pin.
8. Always use the brakes on each of the front swiveling castors to prevent the vehicle moving unintentionally once supported clear of the ground.
9. Repeat the process with the other tyres and jacks (if purchased). Use two jacks to move the front or back of the vehicle. Use four jacks for complete mobility.
10. To lower the jack, remove the locking pin and open the release valve by turning the thumb-wheel slowly counter-clockwise.

- The beams of the jack should move apart under the weight of the vehicle and the jack may be removed when the rollers are no longer bearing any weight.
- To move the front or back of the car you will require two jacks. To position the whole car and move it around you will require four jacks.

---

## CLEANING AND MAINTENANCE

---

If the jack has been stored for long periods, check for oil leaks before use and top up via the oil plug on the side of the oil tank if necessary.

Oil can be topped up using Clarke Hydraulic Oil, part no. 3050830 for 1 litre, part no. 3050835 for 5 litres).

In the event of damage or broken components, replacements are available from Clarke Parts & Service.

## TROUBLESHOOTING

Problem	Reason	Solution
Jack will not raise wheel off the ground.	Low oil level	Check for leakage and up if required via the oil level plug.
	Air in cylinder	Pump pedal to purge air from system.
	O-ring worn.	Return to your dealer for overhaul.
Jack will not hold load and beams move slowly apart.	Release valve not tightly closed.	Speak to the Clarke Service Department
	Release valve not seating.	Return to your dealer for overhaul.
Jack does not lower naturally when valve is opened.	Vehicle tyre under-inflated. (Rollers unable to rotate)	Inflate tyre to correct pressure.

## STORAGE

1. Store in a dry place with the ram fully retracted and the foot pedal held by the pedal locking hook.

# PARTS DIAGRAMS

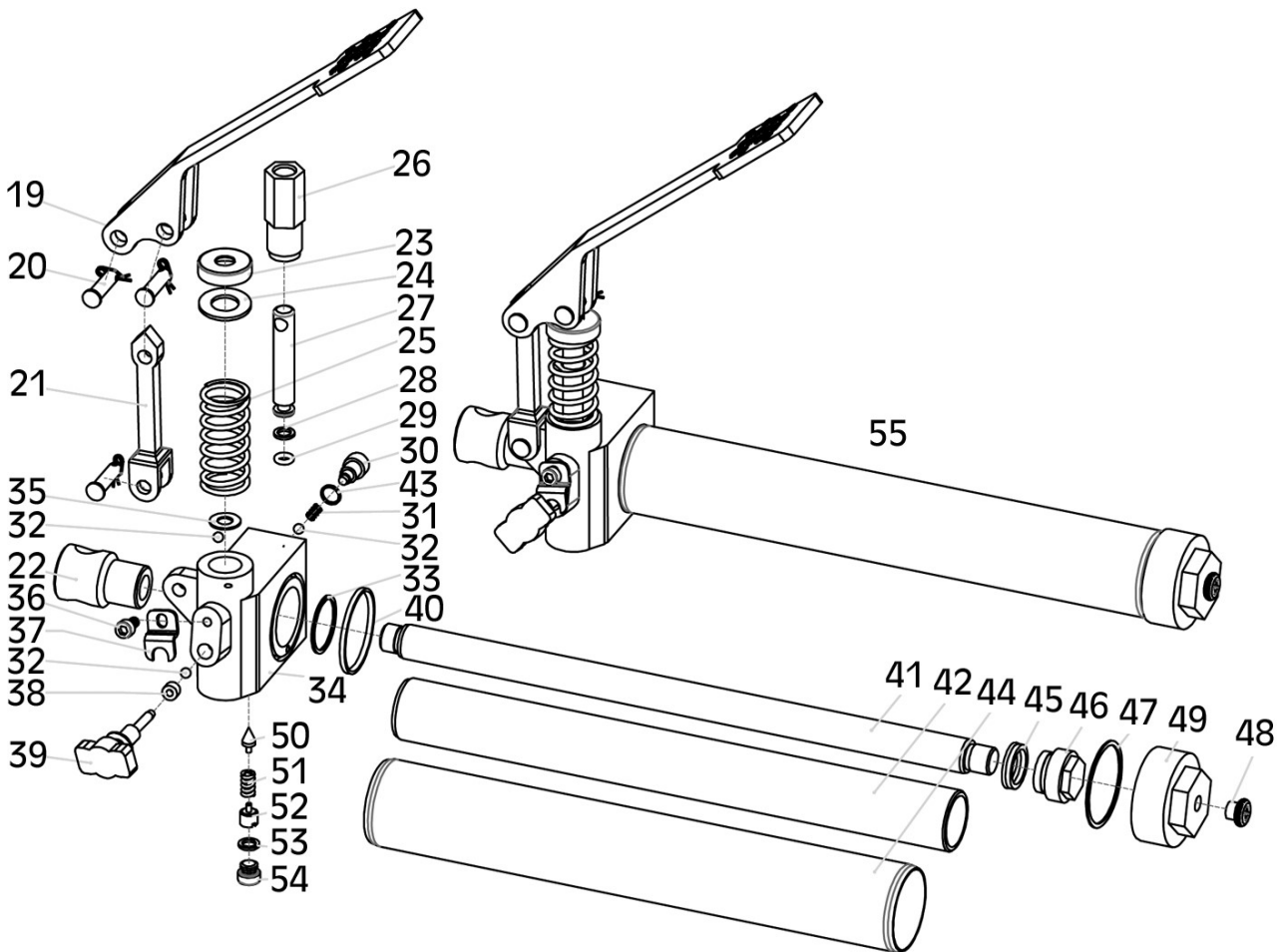
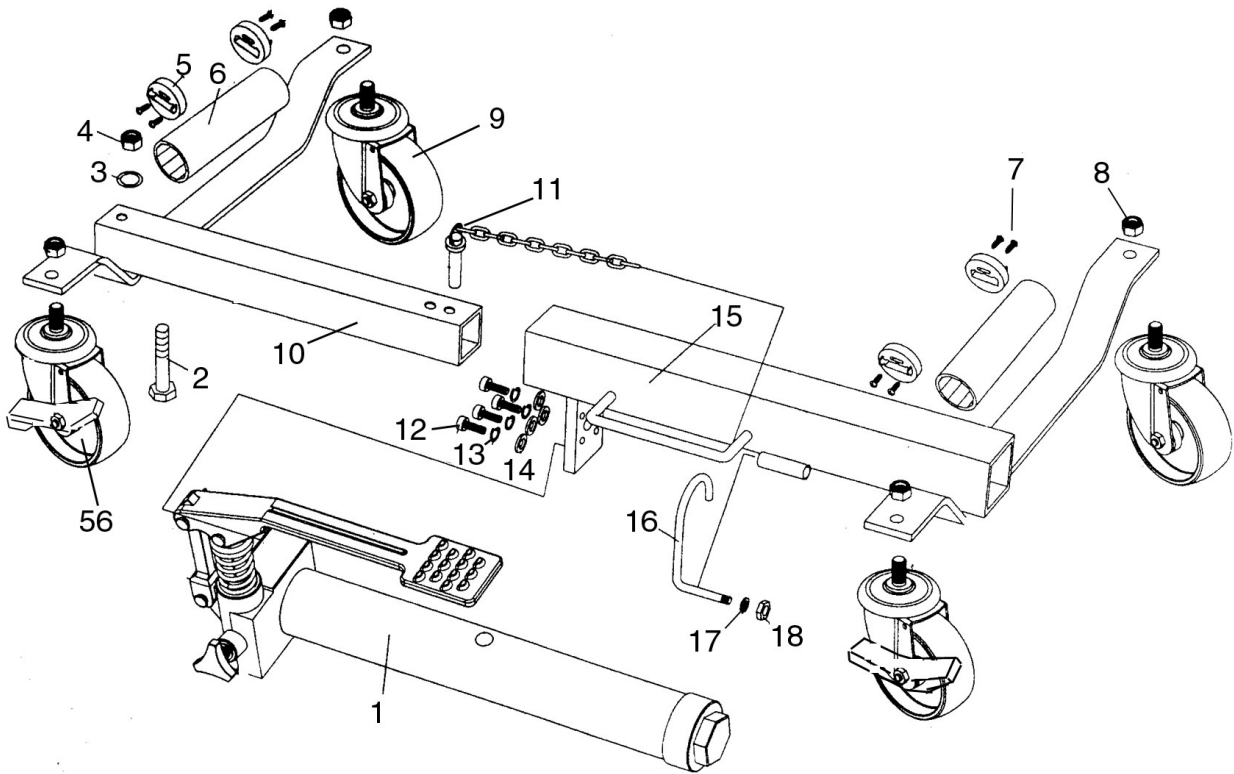



## PARTS LIST

No	DESCRIPTION
1	Ram Assembly
2	Bolt M16x115mm
3	Flat Washer 16mm
4	Nut M16
5	Roller Guide Block
6	Roller Tube
7	Locking Screw
8	Locknut M12
9	Swivel Caster (unbraked)
10	Inner Frame
11	Lock Pin with chain
12	Socket Head Bolt M6x20
13	Lock Washer 6mm
14	Flat Washer 6mm
15	Outer Frame
16	Clasp Hook
17	Washer
18	Nut
19	Foot Pedal
20	Hinge Pin 8 x 28
21	Connecting Arm
22	Connecting Bolt
23	Spring Cover
24	Flat Washer
25	Spring
26	Pump Actuator
27	Pump Piston
28	O-ring

No	PART NUMBER
29	Secondary O-ring
30	Grubscrew M10x1,25
31	Small Spring
32	Steel Ball 6 dia
33	Copper Washer
34	Ram Base
35	Copper Washer
36	Hex Socket Screw
37	Protective Cover
38	Sealing Ring
39	Release Thumbwheel
40	Tank Washer
41	Ram
42	Cylinder
43	Tank Washer
44	Oil Tank
45	End Seal
46	Piston End Cap
47	Piston O-ring
48	Oil Plug
49	Tank End Cap
50	Pressure Adjusting Cone Valve
51	Safety Valve Spring
52	Safety Valve Screw
53	Back Up Ring
54	Screw Cap
55	Ram Assembly
56	Swivel Caster (braked)

# DECLARATION OF CONFORMITY



Hemmill Street, Epping, Essex CM16 4LG

## DECLARATION OF CONFORMITY

This is an important document and should be retained.

We hereby declare that this product(s) complies with the following statutory requirement(s):

*Supply of Machinery (Safety) Regulations 2008*

The following standards have been applied to the product(s):

*EN ISO 12100:2010*

The technical documentation required to demonstrate that the product(s) meet(s) the requirement(s) of the aforementioned legislation has been compiled and is available for inspection by the relevant enforcement authorities.

The UKCA mark was first applied in: 2022

Product Description: 12" Hydraulic Vehicle Positioning Jack  
Model number(s): VPJ300  
Serial / batch Number: N/A  
Date of Issue: 04/01/2023

Signed:

J.A. Clarke  
Director



Fitzwilliam Hall, Fitzwilliam Place, Dublin 2

## DECLARATION OF CONFORMITY

This is an important document and should be retained.

We hereby declare that this product(s) complies with the following directive(s):

*2006/42/EC Machinery Directive*

The following standards have been applied to the product(s):

*EN ISO 12100:2010*

The technical documentation required to demonstrate that the product(s) meet(s) the requirement(s) of the aforementioned directive(s) has been compiled and is available for inspection by the relevant enforcement authorities.

The CE mark was first applied in:

Product Description: 12" Hydraulic Vehicle Positioning Jack  
Model number(s): VPJ300  
Serial / batch Number: N/A  
Date of Issue: 04/01/2023

Signed:

J.A. Clarke  
Director

## USEFUL ITEMS FROM THE CLARKE RANGE

### Trolley Jacks



Low profile jacks ideal for the home mechanic or professional. Choose from the range of quick lift, steel or aluminium.

### Impact Wrenches



A range for garage/workshop use including mains or cordless and also supplied complete with impact sockets

### Engineering Drill Presses



Available for the hobbyist or professional. Ideal for fast, accurate drilling of metal and plastic. Choose from bench or floor mounted.

### Bench Grinders



DIY, professional & heavy duty bench grinders, ideal for grinding garden and workshop tools and general metalworking

# A SELECTION FROM THE VAST RANGE OF

# Clarke®

## QUALITY PRODUCTS



**AIR COMPRESSORS**  
From DIY to industrial, Plus air tools, spray guns and accessories.

**GENERATORS**  
Prime duty or emergency standby for business, home and leisure.

**POWER WASHERS**  
Hot and cold, electric and engine driven - we have what you need

**WELDERS**  
Mig, Arc, Tig and Spot. From DIY to auto/industrial.

**METALWORKING**  
Drills, grinders and saws for DIY and professional use.

**WOODWORKING**  
Saws, sanders, lathes, mortisers and dust extraction.

**HYDRAULICS**  
Cranes, body repair kits, transmission jacks for all types of workshop use.

**WATER PUMPS**  
Submersible, electric and engine driven for DIY, agriculture and industry.

**POWERTOOLS**  
Angle grinders, cordless drill sets, saws and sanders.

**STARTERS/CHARGERS**  
All sizes for car and commercial use.



## PARTS & SERVICE: 0208 988 7400

**Parts Enquiries**  
[Parts@clarkeinternational.com](mailto:Parts@clarkeinternational.com)

**Servicing & Technical Enquiries**  
[Service@clarkeinternational.com](mailto:Service@clarkeinternational.com)

SALES: UK 01992 565333 or Export 00 44 (0)1992 565335

**Clarke** INTERNATIONAL Hemnall Street, Epping, Essex CM16 4LG  
[www.clarkeinternational.com](http://www.clarkeinternational.com)